



Undercover-Sprinklers –
recessed and concealed sprinklers

*Cool down.
Fire Protection by*

MINIMAX

NOTICEABLY well designed

Sprinklers from the Minimax Undercover product range are the perfect solution when it comes to integrating a fire extinguishing system into a ceiling unobtrusively and harmoniously. They are exactly what is required when high aesthetic standards need to be met in prestigious settings such as luxury hotel rooms, museums, showrooms of department stores or offices.

Architects and clients with a keen eye for design invariably consider conventional sprinkler heads and traditional escutcheons that protrude from the ceiling to be unattractive and highly conspicuous. Virtually flush with the ceiling and available in a surface finish to match your interior design, the innovative Undercover-Sprinklers open up a whole host of new interior design opportunities. In addition, they continue to meet the official prerequisites for planning permission to be granted and for premium rebates on fire insurance to be guaranteed.

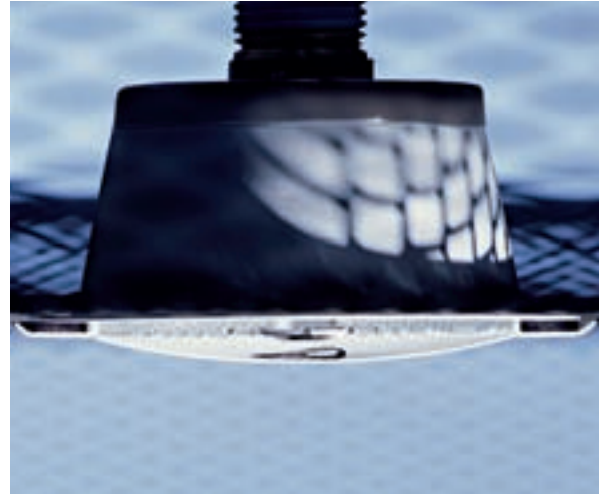

Installation

Undercover-Sprinklers can be installed wherever there are suspended ceilings (e.g. gypsum board or AMF ceiling systems) and solid concrete ceilings (e.g. exposed concrete) with enough available space for the sprinkler housings. These are not installed until the ceiling has been completed and are then seated flush with the ceiling. The height can then be adjusted by up to 15 mm.

Undercover-Sprinklers fit onto all standard arm pipes with drops or flexible stainless steel hoses. Once the sprinkler has been installed, the hydraulic pressure test of the pipe network can be conducted before the suspended ceiling is put in place.

Office buildings



Examples of areas of application for Undercover-Sprinklers

Museums



UNNOTICEABLE

and flush with the ceiling

Highly reliable

There are a number of reasons why Undercover-Sprinklers are so reliable. For a start, there are no moving pieces or parts prone to corrosion. The ornamental ring or the fine-mesh cover are not positively soldered to the housings, but are attached magnetically. There are no vent holes in the Undercover-Sprinklers' housings, and they can therefore not be inadvertently cooled down by the water from cavity sprinklers arranged above them.

If you need a concentrated sprinkler arrangement, the stipulated minimum spacing between two Undercover-Sprinklers installed flush with the ceiling can be easily reduced without having to install baffles, for example. These sprinklers can even be installed in solid ceilings – with no adverse effect on their response sensitivity.

Attractive design

We can meet practically any customer requirement when it comes to the colour of your sprinklers, even above and beyond the RAL colours, so that they will harmoniously blend in to their surroundings.

The sprinkler housings and the suspended sprinkler come in a highly polished chrome finish as standard. The fine-mesh cover and the ornamental ring are available in a choice of white and highly polished chrome.

Protected against soiling and damage

The fact that they are recessed offers the sprinklers greater protection from being damaged by external influences, thus significantly reducing the likelihood of water damage caused by a damaged sprinkler. In addition, Undercover-Sprinklers are consequently less prone to soiling.



 In accordance with DIN EN 12259-1, concealed and recessed Undercover-Sprinklers have been issued with a CE conformity certificate by VdS Schadenverhütung GmbH.

ROUND-THE-CLOCK

safety

Recessed Undercover-Sprinklers

Usually, up to half of the release element of a standard recessed sprinkler protrudes from the ceiling.

- ▶ Recessed Minimax Undercover-Sprinklers are currently the only recessed sprinklers known of to have a sprinkler deflector which is virtually flush with the ceiling. Consequently, they are often also referred to as being "fully recessed".
- ▶ They are optionally available with a visually attractive ornamental ring and can be easily converted to concealed sprinkler.
- ▶ Low response sensitivity of the release element:
RTI value < 50.



Recessed Undercover-Sprinkler

Concealed Undercover-Sprinklers

With its fine-mesh cover and innovative CoverDrop eject mechanism, the Minimax Undercover-Sprinkler is unique amongst the known concealed sprinklers.

- ▶ Thanks to CoverDrop, the fact that the cover unsolders before the sprinkler is triggered does not have any bearing on the sprinkler's reliability.
- ▶ Low response sensitivity of the release element:
RTI value < 50.



Concealed Undercover-Sprinkler

Design and function

Minimax has come up with two different types of the Undercover-Sprinkler – a recessed and a concealed version. Unlike the concealed sprinkler with its fine-mesh cover and the innovative CoverDrop eject mechanism, the recessed Undercover-Sprinkler's head is visible through the optional ornamental ring. Both versions are equipped with the suspended quick-response spray sprinkler, which is a tried and tested Minimax component. The sprinkler unit consists of the sprinkler itself, a base plate with a bayonet socket for attaching the housing, and a thread sleeve.

Advantages

The construction is carefully designed down to the smallest detail and comprises the following benefits:

- ▶ maximum functional reliability
- ▶ unobtrusive and attractive design
- ▶ recessed installation offers protection from soiling and damage

Cross section of an Undercover-Sprinkler

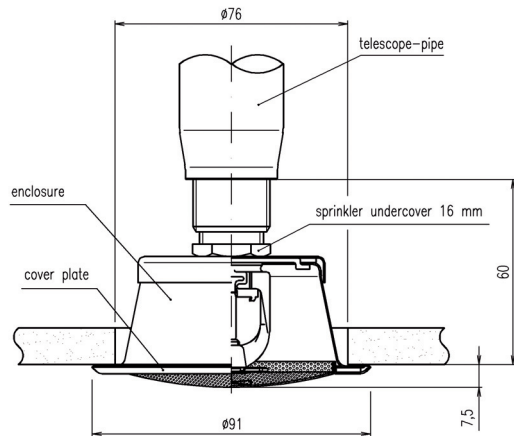

Unique: CoverDrop eject mechanism

The patented CoverDrop eject mechanism is based on two redundant mechanisms. A prestressed spring, held with soldered joint under tension, is fasten on the inside of the fine-mesh cover. When the soldering material's nominal release temperature is reached, this being below that of the sprinkler's release temperature, the pre-stressed spring is unleashed and the fine-mesh cover is ejected. If, under exceptional circumstances, the sprinkler should be triggered before the cover is ejected, the water released by the sprinkler is enough to dislodge the screen, thereby guaranteeing that the water is distributed evenly in all cases.

Tested and approved:
After successful completion of the VdS examinations, Minimax is now the first manufacturer of a VdS-approved concealed sprinkler.



IN USE

everywhere

Areas of application

Undercover-Sprinklers are used in LH, OH1, OH2 and OH3 risk scenarios, as defined by VdS CEA 4001.



These include:

- ▶ Banks
- ▶ Churches
- ▶ Department stores and shopping centres
- ▶ Hospitals, old people's homes and other care institutions
- ▶ Hostels, apartment blocks
- ▶ Hotels
- ▶ Libraries
- ▶ Multi-storey/underground car parks
- ▶ Museums
- ▶ Offices and administrative departments
- ▶ Official and governmental buildings
- ▶ Penal institutions and young offenders' institutions
- ▶ Railway stations
- ▶ Restaurants
- ▶ Schools, universities and other educational institutions



PE07We/10.06/5/09.08/HA



Distributør av Minimax
systemer og produkter i Norge

Maxitech.no kontakt@maxitech.no